

TriPod™ Series

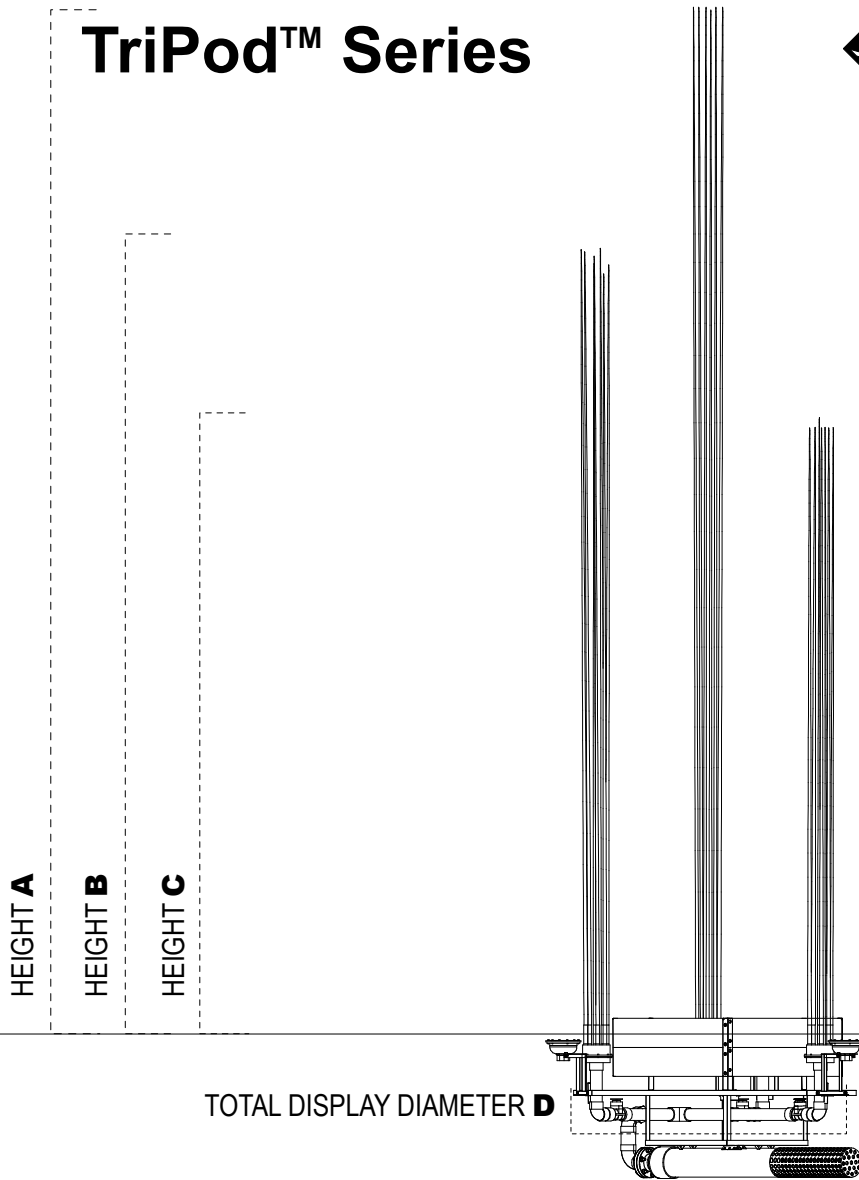

CHECK EITHER WITH OR WITHOUT LIGHTS

Fountain Only										
With Lights										
HP	10	10	10	15	15	15	20	20	30	30
Volts	230	230	460	230	230	460	230	460	230	460
Phase	1	3	3	1	3	3	3	3	3	3
AMP	51	32	16	72	47	24	61	30	90	45
HT. A	20'	20'	20'	25'	25'	25'	30'	30'	40'	40'
HT. B	15'	15'	15'	20'	20'	20'	25'	25'	30'	30'
HT. C	10'	10'	10'	15'	15'	15'	20'	20'	25'	25'
Dia. D	10'	10'	10'	12'	12'	12'	12'	12'	12'	12'
Lights	3	3	3	3	3	3	3	3	3	3
Total Watts	3000	3000	3000	3000	3000	3000	3000	3000	3000	3000
AMP Draw	30	30	30	30	30	30	30	30	30	30

Notes:

1. Drawings are for illustration only and are not to scale
2. Installation of all fountain equipment shall be in accordance with Manufacturer's guidelines and specifications

Vertex Water Features

2100 NW 33rd Street Pompano Beach, FL 33069
 PH: 800-432-4302 FX: 954-977-7963
www.vertexwaterfeatures.com

TriPod™ Specifications

"TYPICAL" TRIPOD™ DESIGN

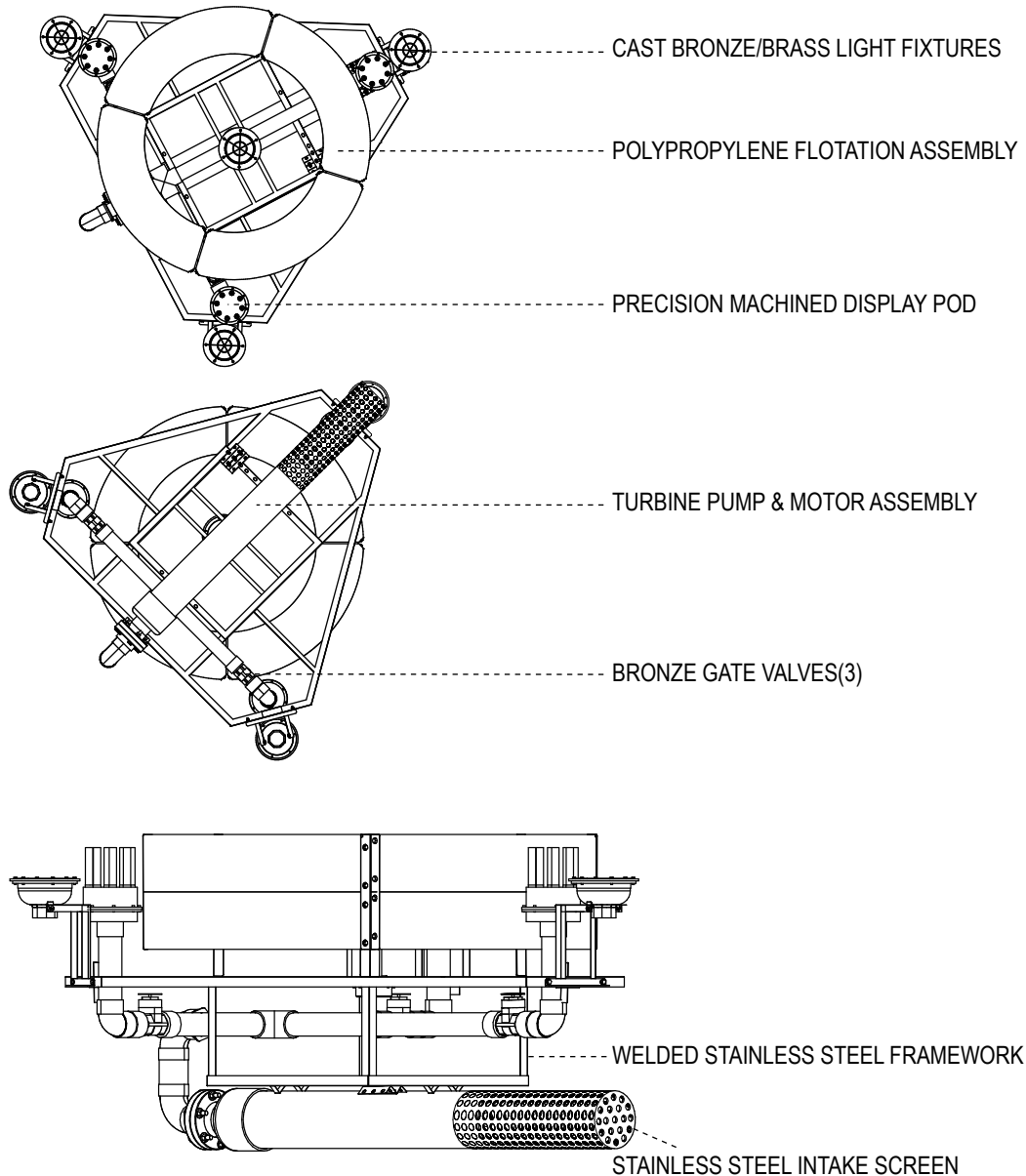

FLOTATION SYSTEM:

Rotocast polypropylene with ultraviolet inhibitors added for extended protection against warping/cracking. Each seamless, watertight section is equipped with threaded brass insert and expanding type fill-plug for addition of water ballast and leveling control.

PUMP/MOTOR:

___ HP, ___ Volt, ___ Phase submersible turbine pump. Driveshaft is 416 stainless steel, supported by bronze bearings above and below each impeller. Pump is equipped with sand collars for maximum protection against abrasives. Stainless steel sealed UL listed submersible motor. Pump and motor are water cooled and lubricated. *Use of oil-filled motors/pumping systems are not acceptable due to need for regular replacement of oil, O-rings, and seals.*

INTAKE SCREEN:

Type 304, 18ga stainless steel, protects against foreign material entering pumping system.

FRAMEWORK:

Type 304 stainless steel with welded joints and stainless steel fastenings.

LIGHTING FIXTURES:

___ 1000watt, 115V Par64 lamps housed in cast bronze/copper UL fixtures with tempered lens, neoprene gaskets; and stainless steel lens protectors, mounting brackets & fastenings. See specification chart for suggested lighting package.

DISPLAY HEAD:

100% precision machined cast bronze and/or brass with stainless steel fastenings provide permanent display characteristics and protection from corrosion. All sidejets are machined into base at precise angles to insure permanent display integrity. *2-piece swivel jets are unacceptable due to inherent ability to become loose and out of adjustment from water pressure and/or pump vibrations. Display heads of plastics, PVC and/or "thermoplastics" are unacceptable.*

UNDERWATER ELECTRICAL CABLES:

STW-A rated, stamped "water resistant". Lengths/gauges to be determined.

FOUNTAIN CONTROL PANEL:

- ◆ Steel NEMA 3R enclosure
- ◆ Capacitive motor starter (single phase units)
- ◆ Phase loss protection (3-phase units)
- ◆ Circuit breaker – pump
- ◆ Circuit breaker – lights (if equipped)
- ◆ GFI protection – lights (if equipped)
- ◆ Surge/Lightning Protection
- ◆ 2 – 24 hour time clocks
- ◆ GFI protection – pump

**Vertex reserves the right to improve and change designs and/or specifications without notice or obligation.*

Floating Fountain Installation Guidelines

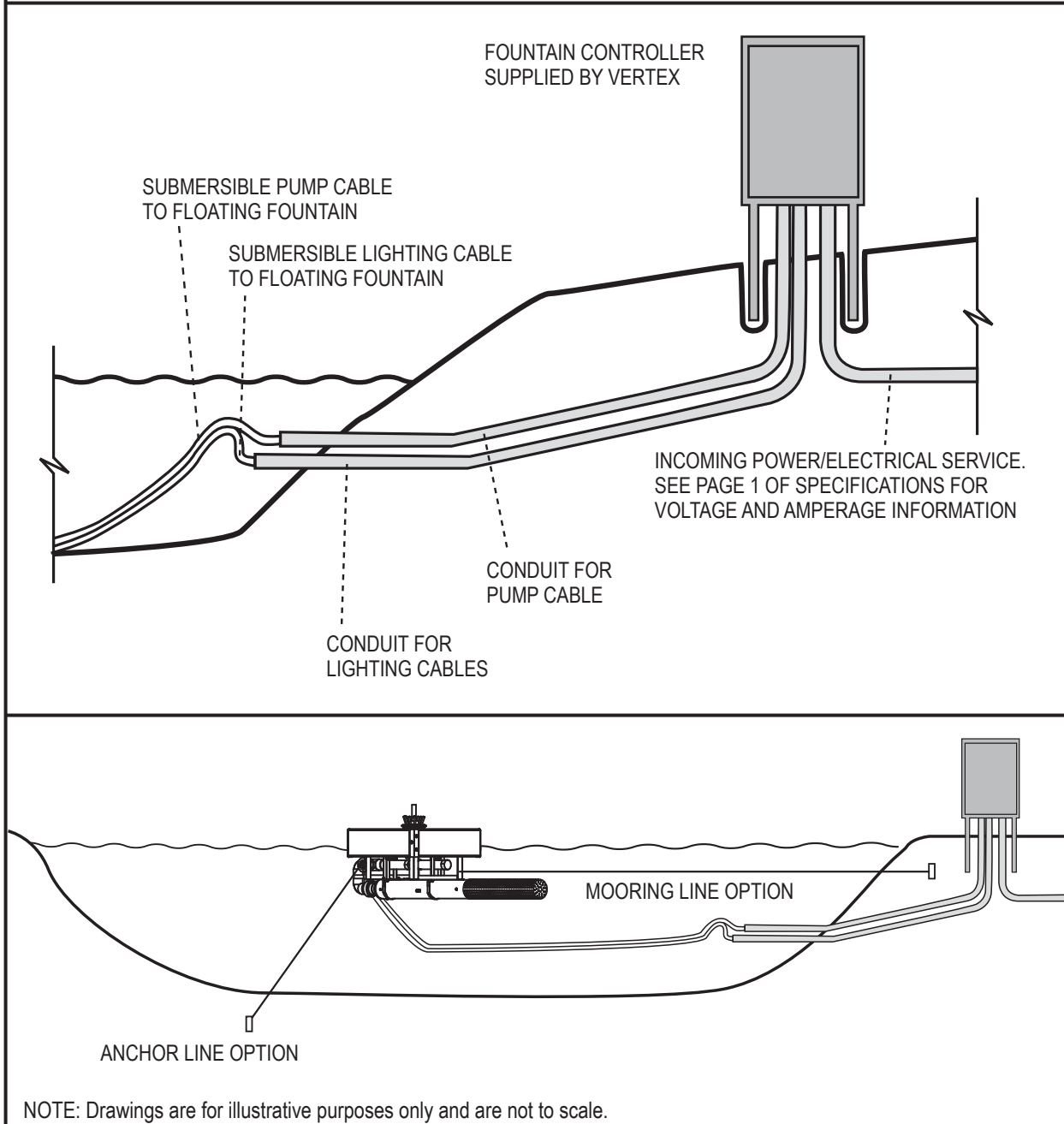

NOTE: Drawings are for illustrative purposes only and are not to scale.

WARNING:

THE FOUNTAIN CONTROL PANEL MUST BE INSTALLED BY LICENSED ELECTRICIAN IN ACCORDANCE WITH ARTICLE 682 OF NATIONAL ELECTRICAL CODE. FAILURE MAY RESULT IN POTENTIALLY HAZARDOUS CONDITIONS AND/OR FAILURE OF ELECTRICAL INSPECTION. CONSULT AUTHORITIES HAVING JURISDICTION (AHJ) FOR SPECIFIC LOCAL CODES / RESTRICTIONS.

Vertex Water Features accepts/assumes no responsibility for installations not in accordance with local and/or national electrical codes.

INSTALLATION OF CONTROL PANEL:

Installation of fountain control panel must be by licensed electrician in accordance with NEC 682 to insure panel location is above any/all possible high water levels. Submergence of panel poses serious risk of electrical shock and damage of fountain system.

SCOPE OF WORK/ELECTRICIAN:

1. Mount NEMA 3R panel enclosure in accordance with NEC 682 in addition to any other local codes and/or restrictions.
2. Trench and bury sufficiently sized conduit(s) from fountain panel to water's edge, extending conduit(s) far enough into water to insure no submersible cable is exposed should low water conditions arise.
3. Bring incoming power from power source into the fountain panel. Incoming voltage must match with specifications of fountain panel or failure will result, damaging the system and voiding the warranty.
4. Pull submersible cable(s) from fountain through conduit to control panel and perform final connections (see Fountain Owner's Manual for more information).

NOTE: Do not operate fountain & lights until fountain installation has been completed and lights are fully submerged. Operating light(s) out of water will result in damage to bulb(s) and lens(es), voiding manufacturer's warranty.

NOTE: Connect only 120V to light(s) – higher voltage will result in immediate damage/failure of bulb(s).