

# Geyser™ Series

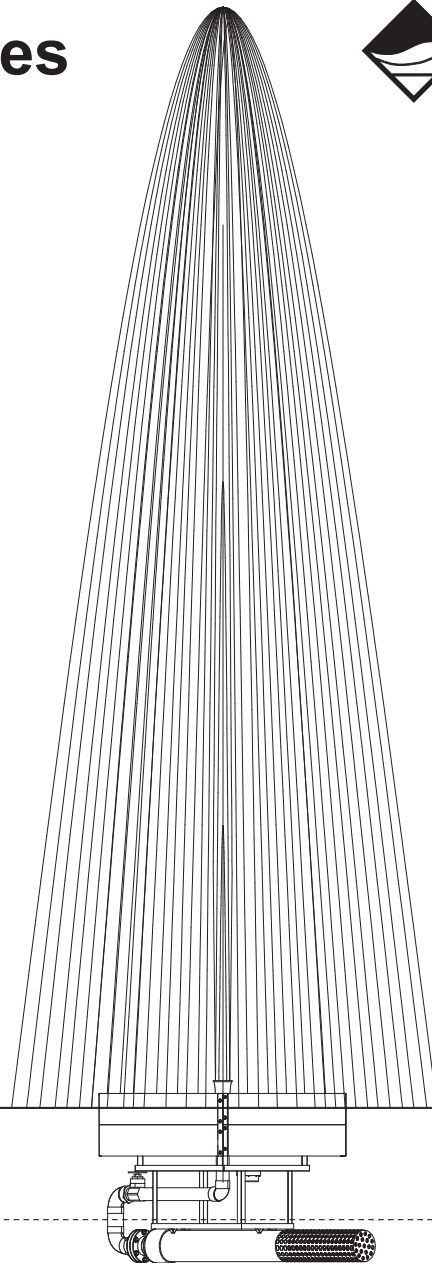

HEIGHT **A**



TOTAL DISPLAY DIAMETER **D**

CHECK EITHER WITH OR WITHOUT LIGHTS

<b>Fountain Only</b>																					
<b>With Lights</b>																					
<b>HP</b>	1	2	2	2	3	3	3	5	5	5	7.5	7.5	7.5	10	10	10	15	15	15	20	20
<b>Volts</b>	230	230	230	460	230	230	460	230	230	460	230	230	460	230	230	460	230	230	460	230	460
<b>Phase</b>	1	1	3	3	1	3	3	1	3	3	1	3	3	1	3	3	1	3	3	3	3
<b>AMP</b>	7	14	8	4	17	10	5	28	17	9	42	25	12	51	32	16	72	47	24	61	30
<b>HT. A</b>	8'	12'	12'	12'	16'	16'	16'	20'	20'	20'	22'	22'	22'	25'	25'	25'	30'	30'	30'	35'	35'
<b>Dia. B</b>	3'	4'	4'	4'	5'	5'	5'	6'	6'	6'	7'	7'	7'	8'	8'	8'	9'	9'	9'	10'	10'
<b>Lights</b>	1	2	2	2	2	2	2	2	2	2	3	3	3	3	3	3	4	4	4	4	4
<b>Total Watts</b>	500	1000	1000	1000	1000	1000	1000	1000	1000	1000	1500	1500	1500	1500	1500	1500	2000	2000	2000	2000	2000
<b>AMP Draw</b>	5	10	10	10	10	10	10	10	10	10	15	15	15	15	15	15	20	20	20	20	20

**Notes:**

1. Drawings are for illustration only and are not to scale
2. Installation of all fountain equipment shall be in accordance with Manufacturer's guidelines and specifications

**Vertex Water Features**

2100 NW 33rd Street Pompano Beach, FL 33069  
 PH: 800-432-4302 FX: 954-977-7963  
[www.vertexwaterfeatures.com](http://www.vertexwaterfeatures.com)

# GeyserJet™ Specifications

## "TYPICAL" GEYSERJET™ DESIGN

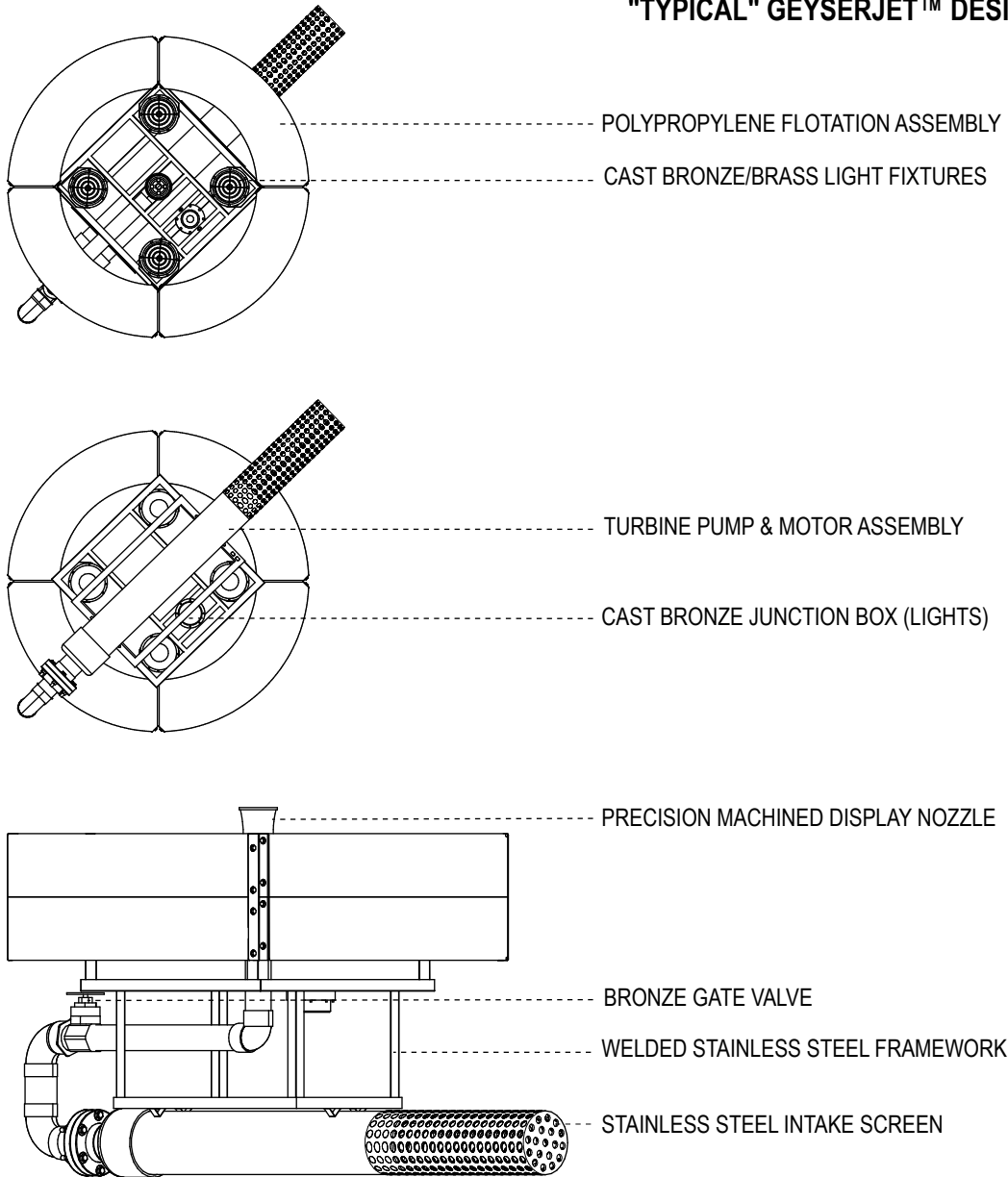

### FLOTATION SYSTEM:

Rotocast polypropylene with ultraviolet inhibitors added for extended protection against warping/cracking. Each seamless, watertight section is equipped with threaded brass insert and expanding type fill-plug for addition of water ballast and leveling control.

### PUMP/MOTOR:

\_\_\_ HP, \_\_\_ Volt, \_\_\_ Phase submersible turbine pump. Driveshaft is 416 stainless steel, supported by bronze bearings above and below each impeller. Pump is equipped with sand collars for maximum protection against abrasives. Stainless steel sealed UL listed submersible motor. Pump and motor are water cooled and lubricated. *Use of oil-filled motors/pumping systems are not acceptable due to need for regular replacement of oil, O-rings, and seals.*

### INTAKE SCREEN:

Type 304, 18ga stainless steel, protects against foreign material entering pumping system.

### FRAMEWORK:

Type 304 stainless steel with welded joints and stainless steel fastenings.

### LIGHTING FIXTURES:

\_\_\_ 500watt, 115V Par56 lamps housed in cast bronze/copper UL fixtures with tempered lens, neoprene gaskets; and stainless steel lens protectors, mounting brackets & fastenings. See specification chart for suggested lighting package.

### DISPLAY HEAD:

Head shall be water-level sensitive Geyser nozzle of 100% brass construction, producing a heavy, active, and highly aerated display. Equipped with integral brass swivel for exacting on-site display adjustments. *Display heads of plastics, PVC and/or "thermoplastics" are unacceptable.*

### UNDERWATER ELECTRICAL CABLES:

STW-A rated, stamped "water resistant". Lengths/gauges to be determined.

### FOUNTAIN CONTROL PANEL:

- ◆ Steel NEMA 3R enclosure
- ◆ Capacitive motor starter (single phase units)
- ◆ Phase loss protection (3-phase units)
- ◆ Circuit breaker – lights (if equipped)
- ◆ GFI protection – lights (if equipped)
- ◆ Surge/Lightning Protection
- ◆ 2 – 24 hour time clocks
- ◆ Circuit breaker – pump
- ◆ GFI protection – pump

*\*Vertex reserves the right to improve and change designs and/or specifications without notice or obligation.*

## Floating Fountain Installation Guidelines

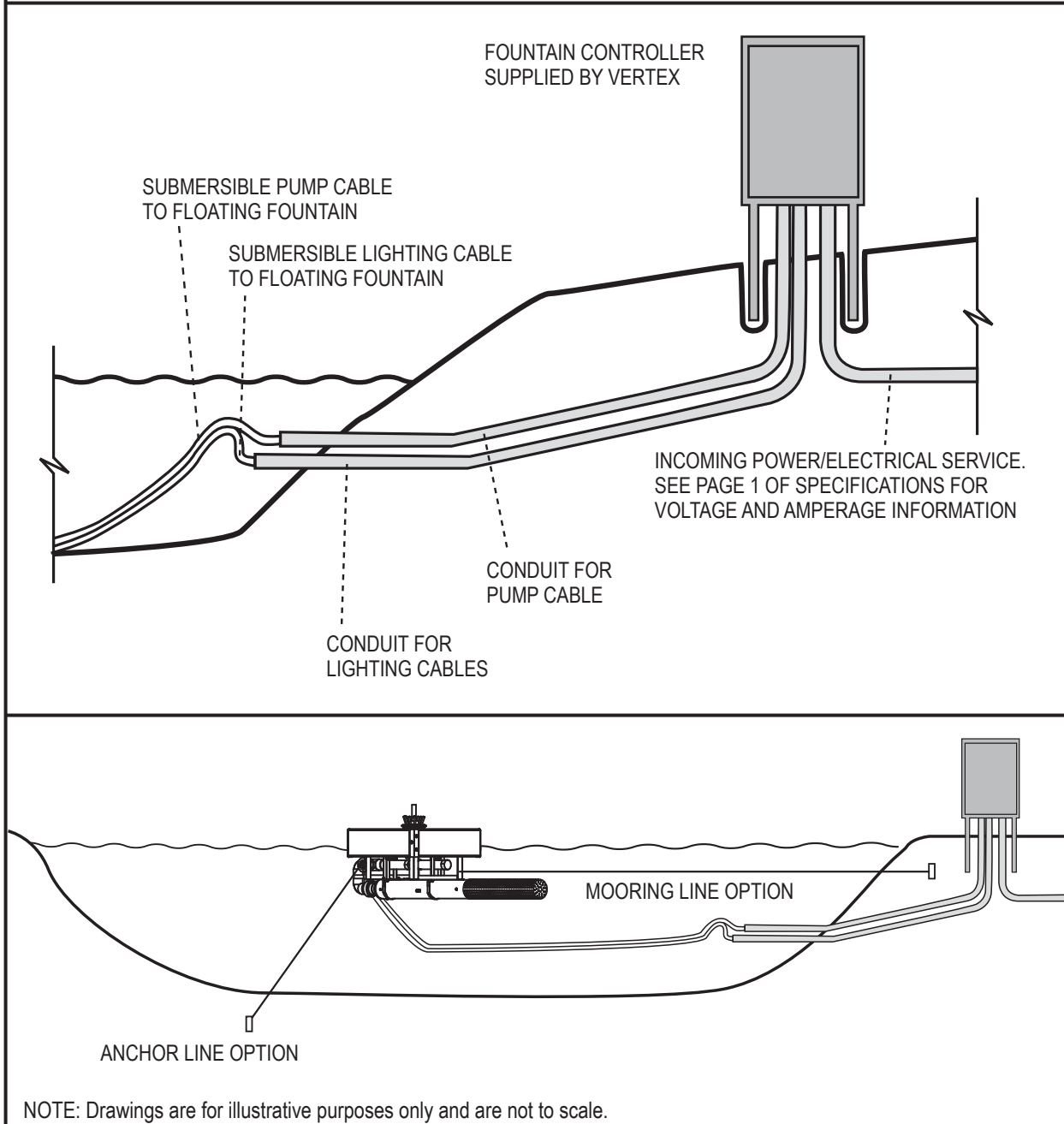

NOTE: Drawings are for illustrative purposes only and are not to scale.

### WARNING:

THE FOUNTAIN CONTROL PANEL MUST BE INSTALLED BY LICENSED ELECTRICIAN IN ACCORDANCE WITH ARTICLE 682 OF NATIONAL ELECTRICAL CODE. FAILURE MAY RESULT IN POTENTIALLY HAZARDOUS CONDITIONS AND/OR FAILURE OF ELECTRICAL INSPECTION. CONSULT AUTHORITIES HAVING JURISDICTION (AHJ) FOR SPECIFIC LOCAL CODES / RESTRICTIONS.

Vertex Water Features accepts/assumes no responsibility for installations not in accordance with local and/or national electrical codes.

### INSTALLATION OF CONTROL PANEL:

Installation of fountain control panel must be by licensed electrician in accordance with NEC 682 to insure panel location is above any/all possible high water levels. Submergence of panel poses serious risk of electrical shock and damage of fountain system.

### SCOPE OF WORK/ELECTRICIAN:

1. Mount NEMA 3R panel enclosure in accordance with NEC 682 in addition to any other local codes and/or restrictions.
2. Trench and bury sufficiently sized conduit(s) from fountain panel to water's edge, extending conduit(s) far enough into water to insure no submersible cable is exposed should low water conditions arise.
3. Bring incoming power from power source into the fountain panel. Incoming voltage must match with specifications of fountain panel or failure will result, damaging the system and voiding the warranty.
4. Pull submersible cable(s) from fountain through conduit to control panel and perform final connections (see Fountain Owner's Manual for more information).

**NOTE:** Do not operate fountain & lights until fountain installation has been completed and lights are fully submerged. Operating light(s) out of water will result in damage to bulb(s) and lens(es), voiding manufacturer's warranty.

**NOTE:** Connect only 120V to light(s) – higher voltage will result in immediate damage/failure of bulb(s).