

FLOATING FOUNTAINS



The TriTier series provides one of the most delicate and aesthetic displays offered. The dramatic 3-tier pattern, with its floral arches created by all brass precision machined nozzle and swivel base (available on 5HP and above nozzles) is available in heights from 15' to 46'.

Powered by a UL listed heavy-duty submersible turbine pump, the TriTier standard equipment includes a complete UL listed control panel.

All fountain components are fully waterproof and made of the finest corrosion resistant materials to provide years of dependability and high performance.

FEATURES AND BENEFITS

PUMPS/MOTORS

- ◆ UL listed, high performance turbine pump motor assembly
- ◆ Stainless steel construction
- ◆ Water cooled: no oils, seals or o-rings to replace
- ◆ 4-year warranty

NOZZLES

- ◆ Precision machined brass/bronze aeration nozzles
- ◆ 4-year warranty

SUBMERSIBLE LIGHT FIXTURES

- ◆ UL listed, cast bronze/copper housing
- ◆ Stainless steel brackets
- ◆ Tempered lenses
- ◆ Bronze/stainless steel lens protectors
- ◆ 2-year warranty

FLOTATION

- ◆ Rotocast polypropylene construction
- ◆ UV inhibitors for long life
- ◆ Individual leveling compartments for exact adjustments
- ◆ 4-year warranty

CONTROL PANEL

- ◆ UL listed per National Electrical Code
- ◆ Weatherproof steel enclosures
- ◆ 1-year warranty

CABLES

- ◆ UL listed, STW-A rated
- ◆ 4-year warranty

CORROSION RESISTANT

- ◆ Cast brass/bronze nozzles
- ◆ Polypropylene float
- ◆ Stainless steel frame and fastenings
- ◆ Bronze/copper lights

BENEFITS TO LAKE

- ◆ Aesthetics – beautifies waterway
- ◆ Increases property value and quality of community
- ◆ Adds a focal point to any community
- ◆ Assists in aeration of lake system, aiding in fish dynamics
- ◆ Through agitation, prevents aggregation of planktonic algae on the surface and helps in reduction of mosquito larvae

TRITIER™ FLOATING FOUNTAIN

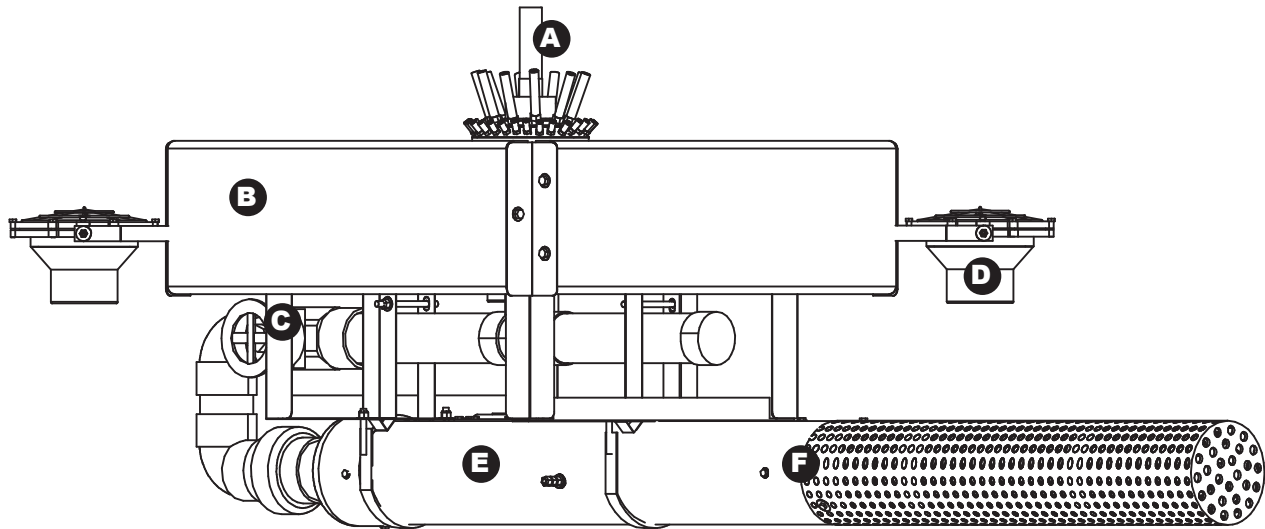

A	PRECISION MACHINED BRASS/BRONZE DISPLAY NOZZLES
B	POLYPROPYLENE FLOTATION ASSEMBLY
C	WELDED STAINLESS STEEL FRAMEWORK

D	CAST BRONZE/BRASS LIGHT FIXTURES
E	TURBINE PUMP MOTOR ASSEMBLY
F	STAINLESS STEEL INTAKE SCREEN

Due to the electric equipment involved, floating fountains are not designed for waterways where swimming or water sports are permitted. Specifications recorded during calm wind conditions. Install all electrical equipment in accordance with Article 682 of the National Electrical Code and all local codes. Vertex Water Features reserves the right to improve and change our designs and/or specifications of our fountains without notice or obligation.

DISPLAY SPECIFICATIONS

HP	1ST HT	2ND HT	3RD HT	# Lights	Total Wattage	Available Phase
1	13'	6'	3'	1	500W	1
2	20'	8'	4'	2	1000W	1, 3
3	25'	10'	5'	2	1000W	1, 3
5	30'	15'	7'	2	1000W	1, 3
7.5	35'	18'	8'	3	1500W	1, 3
10	40'	20'	9'	4	2000W	1, 3
15	45'	25'	10'	4	2000W	1, 3

PUMP AMPERAGE

(208V & 460V 3-phase motors available)

HP	230V10	230V30
1	7	-
2	14	8
3	17	10
5	28	17
7.5	42	25
10	51	32
15	72	47

LIGHTING SPECIFICATIONS

Total Wattage	500	1000	1500	2000	2500	3000	3500	4000
AMP Draw	5	10	15	20	25	30	35	40

© 2009 Vertex Water Features



2100 NW 33rd Street Pompano Beach, FL 33069
 Phone: 800-432-4302 Fax: 954-977-7963
www.vertexwaterfeatures.com